



OPUS[®] II

Our latest innovation of Optimized Pretreatment and Unique Separation Technology



Solutions & Technologies

OPUS® II technology is a proprietary Optimized Pretreatment Unique Separation technology developed to achieve high recovery of clean water for reuse or discharge. This new generation of OPUS technology is a compact design that results in lower installed costs than comparable systems.

Developed by Veolia Water Solutions & Technologies, this unique technology utilizes our proprietary CeraMem® ceramic membranes with chemical and ion exchange softening as pretreatment to a reverse osmosis (RO) process operated at an elevated pH. The result is a compact treatment system that provides high quality water suitable for reuse in industrial processes or replenishment of raw water sources.

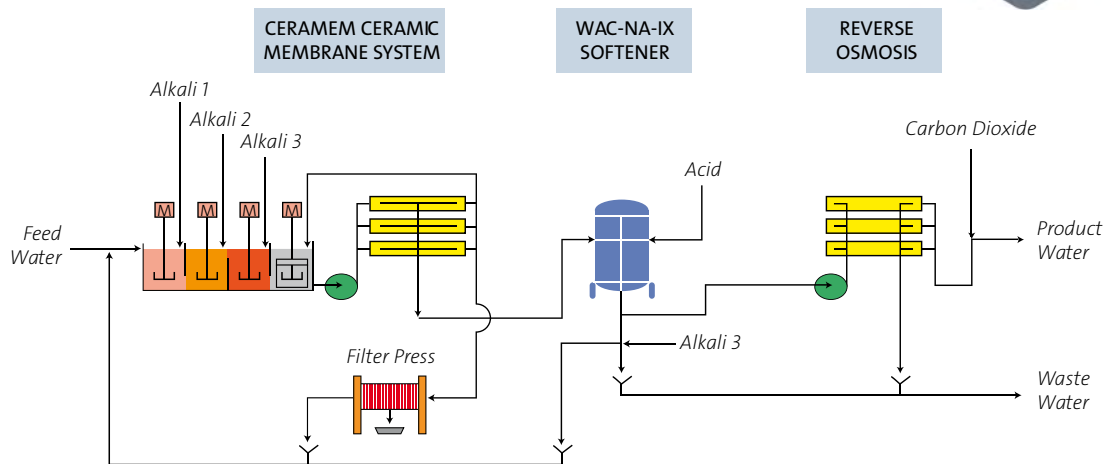
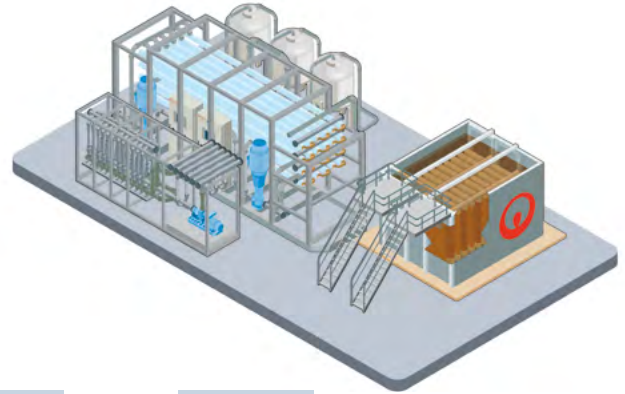

Technology Description

OPUS II technology consists of multiple treatment processes involving chemical softening, membrane filtration, ion exchange softening and reverse osmosis operated at an elevated pH. The pretreatment processes ahead of the RO are designed to reduce free oil, hardness, metals and suspended solids in the feed water. The RO process operates at an elevated pH, which effectively controls biological, organic and particulate fouling, eliminates scaling due to silica and increases the rejection of silica, organics and boron.

In the OPUS II technology, the feed water is subjected to chemical softening, free oil and solids removal in a pretreatment process that uses CeraMem ultrafiltration technology. This process consists of a series of reaction tanks followed by a crystallization tank fitted with our patented Turbomix® mixing technology, which facilitates precipitation of hardness and metals in the feed water and crystallization of the solids generated by precipitation. The softened water and crystalline solids are then processed through the ceramic membrane ultrafiltration system operated in cross-flow mode for removal of free oil, total hardness and suspended solids to lower concentrations. The solids waste from the CeraMem process is continuously recycled to the crystallization tank and purged intermittently for dewatering and subsequent hauling to landfill for disposal.

The filtrate from the CeraMem process is further treated with ion exchange softening utilizing Weak Acid Cation (WAC) resin in sodium form for further removal of hardness and metals to lower concentrations, without pH correction. The pretreated water is then pressurized through the RO, operated at an elevated pH in single or double pass mode, to reduce the TDS, boron and organics.

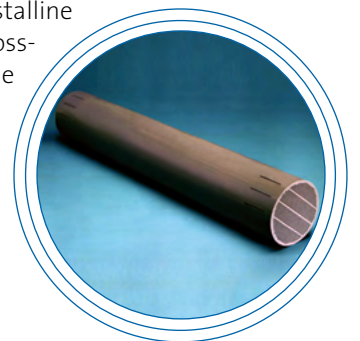

Technology Benefits

- >90% recovery rate up to 7,500 ppm influent TDS
- Compact, modular systems with low field installation costs
- Prevents scaling caused by silica, calcium and metal salts
- Controls fouling due to organics and particulates
- Achieves salt rejection removal rates of >99.4% boron, >99.7% silica and >99% TOC
- Continuous Clean-In-Place (CIP) process minimizes RO cleaning frequency
- 3-year pro-rated membrane life warranty
- Robust treatment approach with minimal system downtime
- Effectively handles variations in feed water quality



Applications

- Oil and Gas Field Produced Water
- Power Plant Cooling Tower Blowdown
- Reuse of Industrial Wastewater to Achieve Zero Liquid Discharge

Guaranteed Performance

Veolia Water Solutions & Technologies offers a performance guarantee after testing OPUS II technology using our mobile pilot system. Our pilot units, capable of treating 20 gallons per minute (685 barrels per day), are deployed to your site to demonstrate the process for your water characteristics before the full-scale system is designed, enabling us to optimize performance and minimize cost. Long-term operation and maintenance contracts are also available to ensure continued optimization of your system and extend the performance guarantee for the life of the contract.

Flexible Project Delivery Options

Our project delivery can be tailored to your purchasing preferences:

- Engineer / Procure
- Design / Build
- Design / Build / Operate / Maintain
- Design / Build / Own / Operate / Maintain

Typical Performance Data

Constituent	Feed Water	CeraMem® Ultrafilter Filtrate	Double Pass RO Permeate	Removal Efficiency
Free Oil (> 20µ), ppm	100	<0.2	Non-Detect	> 99.9%
Total Suspended Solids, ppm	100	<0.2	Non-Detect	> 99.9%
Total Hardness, ppm as CaCO ₃	236	<10	Non-Detect	> 99.9%
Calcium, ppm	65	<3.2	Non-Detect	> 99.9%
Magnesium, ppm	18	<0.5	Non-Detect	> 99.9%
TDS, ppm	2,200	2,500	<15	> 99.3%
Boron, ppm	8.6	8.6	<0.03	> 99.7%
Silica, ppm	220	<50	<0.03	> 99.9%
Organics, ppm	210	210	<0.99	> 99.5%



Veolia Water Solutions & Technologies is committed to delivering sustainable solutions and resource recovery based on three key principles:

Service is what we provide our customers. We offer customer care at its best, not only through operation and maintenance contracts and asset management, but also aftermarket field services and Hydrex™ chemicals.

Value is what we create for our customers. We seek opportunities for recycle and reuse of resources, product recovery and energy production as part of our water treatment processes. For each project, we look for ways to add value for our customers.

Responsibility is the cornerstone of all our business activities. As part of Veolia Environnement, the world's largest environmental company, we understand the importance of our social responsibility to protect the resources of our planet for future generations. We utilize tools such as Carbon Footprint evaluation and Water Impact Index to help our customers achieve their corporate sustainability goals.



+1-800-337-0777
www.nawatersystems.com
water.info@veoliawater.com

VWS Photo Library/Veolia Photo Library/Jean-François Pellegry - VWS Communications 2011